

Use existing Ladder Stop Upright

6' LADDER ADAPTER PLATE

LOCATE FRONT LADDER STOP IN DESIRED POSITION & DRILL 3/8 HOLE THRU TOP OF ANGLE FLANGE, FASTEN WITH 5/16X 3/4 CARRIAGE BOLT, FLAT WASHER, LOCK NUT.

CLAMP ADAPTER IN POSITION & INSERT # 10-16 X 5/8 SELF TAPPING SCREW

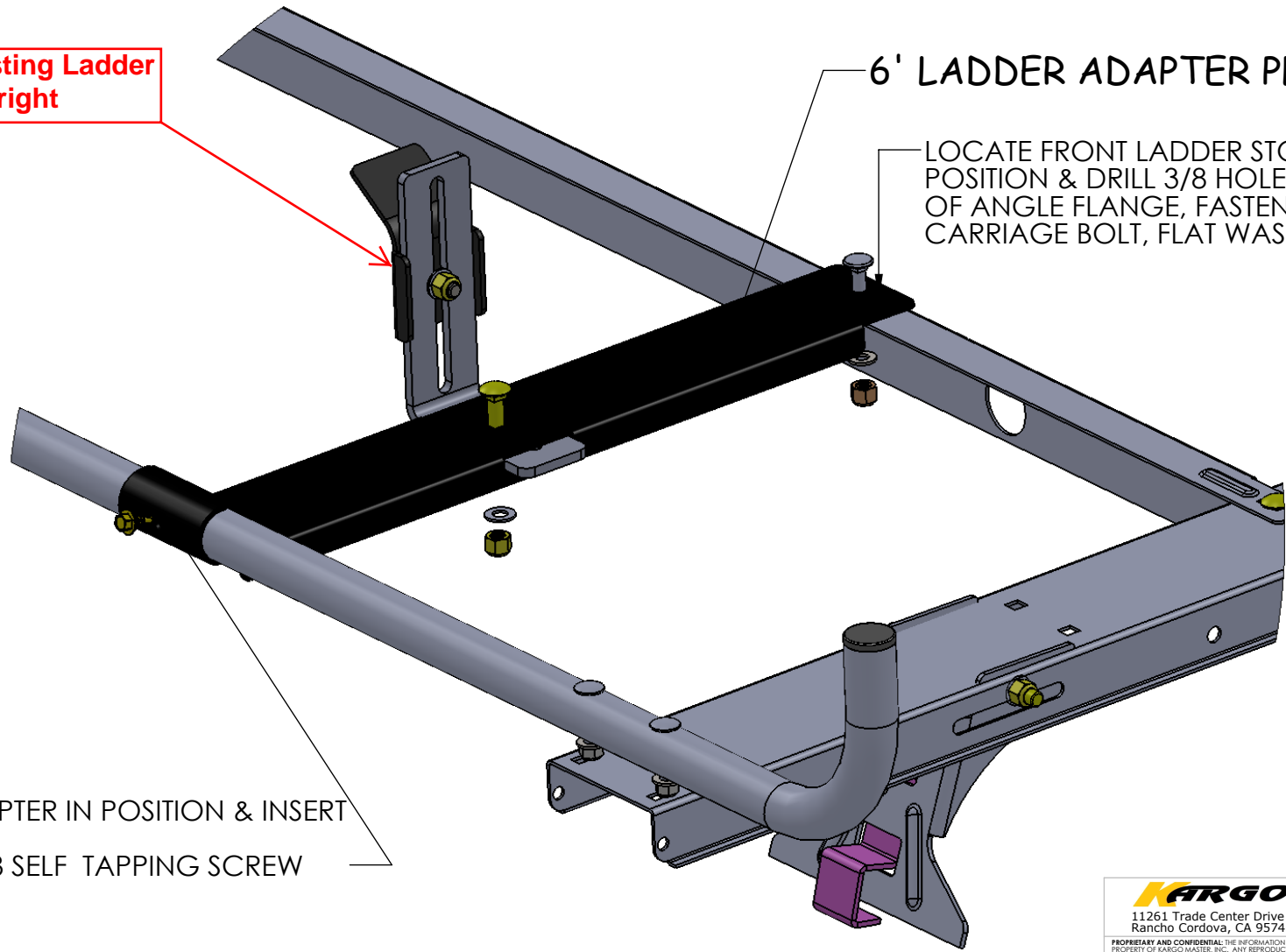

**KARGO MASTER**<sup>®</sup>  
11261 Trade Center Drive Tel 916-638-8703  
Rancho Cordova, CA 95742 Fax 916-638-0177

PROPRIETARY AND CONFIDENTIAL THE INFORMATION CONTAINED IN THIS DRAWING IS THE SOLE PROPERTY OF KARGO MASTER, INC. ANY REPRODUCTION IN PART OR AS A WHOLE WITHOUT THE WRITTEN PERMISSION OF KARGO MASTER, INC. IS PROHIBITED.

Description: REV

DWG #: 40803 SIZE A

UNLESS OTHERWISE SPECIFIED:  
DIMENSIONS ARE IN INCHES  
TOLERANCES:  
FRACTIONS: 1/32  
ANGULAR: ± 1°  
TWO PLACE DECIMAL: ±0.01  
THREE PLACE DECIMAL: ±0.004

SCALE 1:32 (ITEM # QTY)

cu. in Wt: lb Sheet 1 of 1